

Medi-tell 2

Disabled Persons Response Alarm.



Engineer / Installation Manual

Document: V148.2

...Protecting People



Ventcroft Ltd
Medi-tell-2 Disabled Person Response (WC) Engineer / Installation Manual

First Printed: 19/07/05
Document :V148
Revision: 2
Last Revised : 19/07/05

Copyright © 2003 by Ventcroft Ltd. All rights reserved. No part of this manual may be reproduced or transmitted in any form or by any means, electronic or mechanical, including photocopying, recording, or by any information storage or retrieval system, without prior written permission from the publisher.

Notice of Liability

Every effort has been made to ensure that this manual / instructions contain accurate and current information. However, Ventcroft Ltd shall not be liable for any loss or damage suffered by the readers as a result of information held herein.

Trademarks

Ventcroft and the Ventcroft logo / device are trademarks of Ventcroft Ltd.
All other trademarks are acknowledged as trademarks of their respective companies.

Ventcroft Ltd
Goddard Road
Astmoor Industrial Estate
Runcorn, Cheshire,
WA7 1NQ, United Kingdom
Tel: +44 (0)1928 581098
Fax: +44 (0)1028 581099
Email: sales@ventcroft.co.uk
Web: www.ventcroft.co.uk

If you have any questions about this product please do not hesitate to ring,
Technical Help : +44 (0)1928 581098

Table of Contents

1.0 Description	4
2.0 Main Features	5
3.0 Kit Contents	6
4.0 Technical Description	7
4.1 Terminal Descriptions	7
4.2 ECU Internal Safety Fuses	8
4.3 Front Mounted LED's and Buttons	9
4.3.1 LED's Description	9
4.3.2 LED Display Types Quick Look Up Guide	9
4.3.3 Green LED – Power	9
4.3.4 Amber LED – Fault	10
4.3.5 Red LED – Call	10
4.4 Front Mounted Mute / Reset / Test Button	11
4.4.1 Muting a “Standard Call”	11
4.4.2 Resetting a “Standard Call”	11
4.4.3 System Sounder / LED Test	11
4.5 Internal Peizo Buzzer	12
5. Installation	12
5.1 General Installation Considerations	12
5.2 Assembly	14
5.2.1 Pull Cord Assembly	14
5.2.2 Over door Indicator	14
5.2.3 Reset Button	15
5.2.4 ECU	15
5.3 System Capacity and VEN Capacity and Ratings	16
5.4 Mounting and Fixing	17
5.5 Wiring and Termination	18
5.5.1 Wiring the ECU	19
5.5.2 Wiring remote devices	20
6.0 Commissioning	21
6.1 Powering Up	21
7.0 Operation and Functionality	21
7.1 Normal Quiescent Mode	21
7.2 Call Mode	21
7.3 Mute A Call at the DPA ECU	22
7.4 Reset A Call	23
7.4.1 From the ECU	23
7.4.2 From a Remote Reset Point	23
7.4.3 From A Master Reset Point	23
7.5 Attendant “Priority Call” Mode	23
7.5.1 Attendant “Priority Call” From “Normal Quiescent” mode	23
7.5.2 During a Standard “Call” Activation	23
7.6 Master Reset a “Priority Call” or a “Call”	24
7.7 Battery Back-Up Standby By Mode	24
7.8 Battery Saver Auto Shut Down	24
8.0 Maintenance and Regular Testing	25
8.1 Regular System Testing	25
8.2 Battery Replacement	25
9.0 Accessories and Spare Parts	26
10.0 Specifications	27
10.1 Ceiling Mount Call Pull Cord	27
10.2 Surface / Flush Mount Remote Reset	27
10.3 Surface / Flush Mount Over Door Indicator	28
10.4 Surface / Flush Mount Interface Device	28
10.5 Battery Backup Device	29
10.6 Priority Call Button	29
10.7 Master Reset Button	30
10.8 Surface / Flush Mount Electronic Control Unit - ECU	31
NOTES:	32

1.0 Description

The *MEDI-TELL 2* disabled person's response alarm has been designed for applications such as disabled persons dwellings i.e. disabled persons toilets. The requirements of BS8300:2001 have been taken into consideration when designing the *Medi-tell 2*.

The Medi-tell 2 system consists of an Electronic control unit (ECU) which is connected to all of the field call, reset and indicator devices.

Field devices consist of three types which provide the Electronic Control Unit with the necessary Input and output signals to allow the system to function.

"Call Devices" can either be ceiling mounted pull cord devices or wall mounted push button devices, they are used to generate an alarm activation by a person in Distress or requiring attention from a carer. When a call device is activated the system will generate an alarm, an indicator LED mounted on all devices will illuminate. "Priority Call Devices" are wall mounted push button devices that can be installed to a system and when activated produces a more urgent alarm to summon other carers.

"Reset Devices" are generally wall mounted and consist of push button devices which are pressed to cancel an alarm activation. Reset devices with a key enable can be installed for key holder only reset.

"Warning Devices" are generally wall mounted which during an alarm activation will alert carers / staff of a person requiring attention. Warning devices typically have a visual and audible element within the same housing, but devices with only audible or visual elements may be fitted to a system.

The Interface device can be used to interface the Medi-tell 2 system to other management systems, sounders, strobes and pagers.

The Medi-tell 2 Electronic Control Unit (ECU) is powered by the mains supply, an optional battery back up can be installed which allows the *MEDI-TELL 2* system to function during mains failure for up to 24 hours.

The Electronics Control Unit (ECU) has a built in buzzer and three front mounted LED's which are used to indicate the status of the system. A green LED indicates the status of the mains power supply, an amber LED will display the fault status of the field devices wiring and power supply, and a red LED indicates the presence of an alarm activation.

The *Medi-tell 2* is very simple to install and utilises a unique two-wire field device wire system, making termination and cabling simple and easy.

The field device wiring uses End-of-Line monitoring to provide cable integrity verification.

2.0 Main Features

- Simple 2 Wire operation for all field devices
- Battery Back up Option
- Simple Maintenance and Self Fault Diagnosis.
- On Board Buzzer (With 'mute' cut link).
- 3 Front Mounted Status LED's
- Front Mounted Mute / Reset / Test Button.
- Full Range of Field Devices Available.
- Simple Field Device [VEN](#) Rating System
- System Integrity End-of-Line Monitoring
- Microprocessor controlled.
- Local or Remote Reset Option
- Battery Saver Auto Shut Down
- Priority Call Point Option
- Master Reset Point With key-Switch Enable
- Simple Interface Device available.

3.0 Kit Contents

VPA-220, Premier System Plastic -Surface Mount Call response control unit, with three status LED's, internal buzzer, mute / reset button and battery back up option complete with selection of field accessories. 330x205x80 (LxWxH).

Contents -

- 1 * Control Unit (VPA-ECU)
- 1 * DPA Pull Cord (VPA-PC)
- 1 * Remote Reset Button (VPA-RM)
- 1 * Over Door Indicator and Sounder (VPA-ODI)
- 1 * Disabled Sticker (VPA-DS1)
- 1 * Deep Base Double Gang Surface Back Box.
- 2 * Slim Base Single Gang Surface Back Box.
- 1 * Engineer / Installation Manual
- 1 * User Manual
- 1 * Accessory Bag Containing:-
 - 1 * 6K8 End Of Line resistor
 - 1 * Spare 500 mA Fuse



VPA-200, Standard System - Surface Mount Call response control unit, with three status LED's, internal buzzer, mute / reset button and battery back up option. 330x205x80 (LxWxH).

Contents -

- 1 * Control Unit (VPA-ECU)
- 1 * DPA Pull Cord (VPA-PC)
- 1 * Disabled Sticker (VPA-DS1)
- 1 * Deep Base Double Gang Surface Back Box.
- 1 * Engineer / Installation Manual
- 1 * User Manual
- 1 * Accessory Bag Containing:-
 - 1 * Spare 6K8 End Of Line resistor
 - 1 * Spare 500 mA Fuse



4.0 Technical Description

This section provides brief technical information about the ECU terminal and functionality.

4.1 Terminal Descriptions

Electronics Control Unit – ECU (VPA-ECU)

Mains	L N E	The Mains terminals are how the ECU receives its main power source. L terminal connects to the Live mains wire, N connects to the Neutral mains wire and E is used to connect to the mains earth wire. It is good practice to fit a Non switched fused spur, fitted with a 1A fuse between the ECU and the mains supply. Any wiring or termination to mains supply should be in accordance with IEE regulations and carried out by a trained and qualified electrician.
Field Device	+ -	The Field Device terminals are used to connect to the field devices, such as Ceiling Pull Cords, Over Door Indicators and Reset Buttons.
Battery	+ -	The Battery Terminals are used to connect the optional external back up battery devices. In the event of mains failure a back up battery will enable the ECU to continue functioning from the charge of the battery, if the mains supply is not returned and the battery is flattened the ECU will automatically enter sleep mode to protect the battery.
Switch	• •	The Switch terminals are used to connect the front mounted Mute/Reset switch, and should not be used.

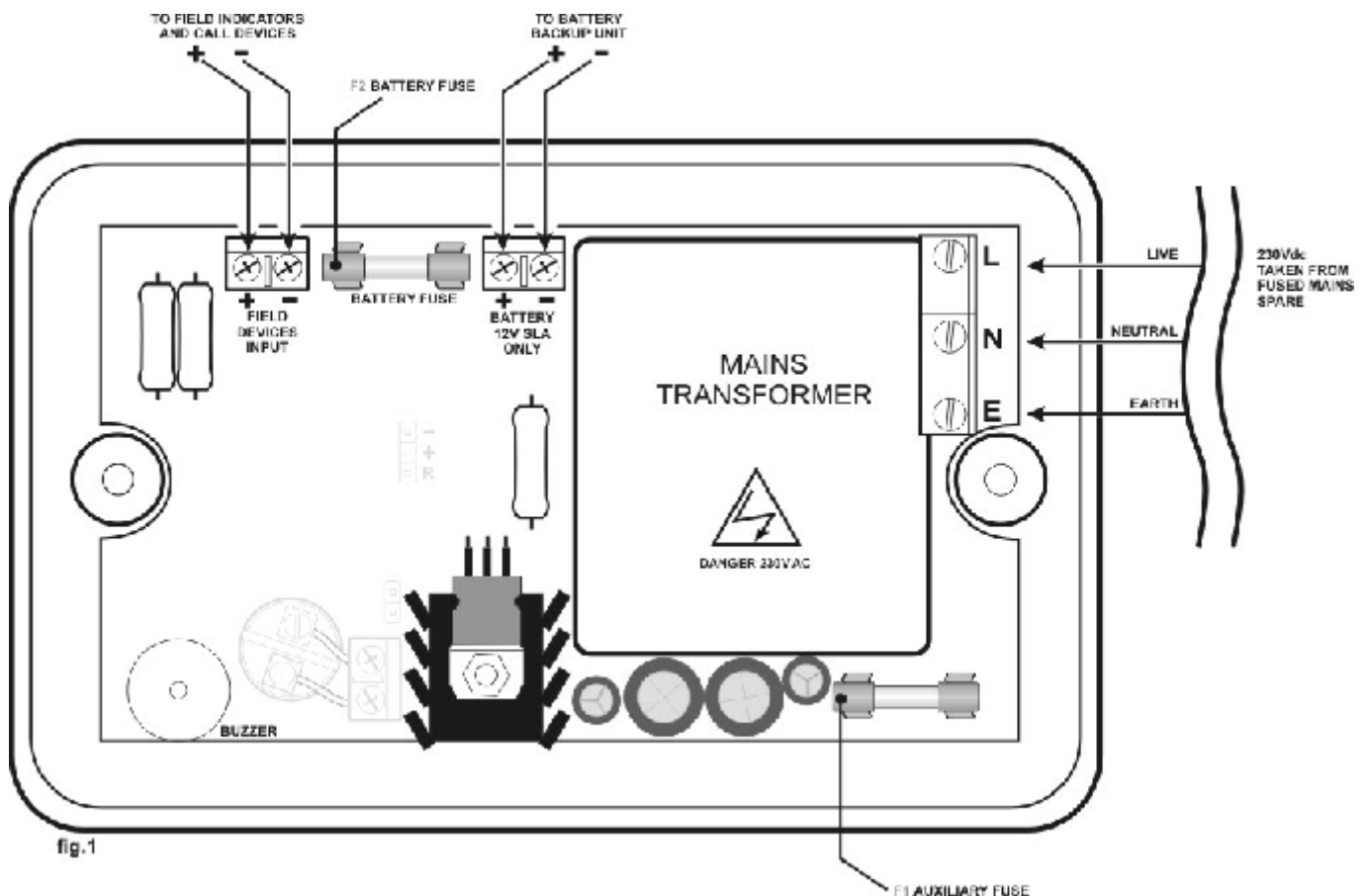

4.2 ECU Internal Safety Fuses

The ECU has 3 internal safety fuses to protect the sensitive electronics from external current overloads short circuits and a thermal transformer fuse to conform to regulations to limit any chance of overload and fire.

4.2.1 F1 – Auxiliary – 500mA, Anti Surge / Timed.

The Auxiliary Fuse protects the ECU circuitry, field devices and field device wiring from current overload. The field device wiring is also protected with electronic current limiting

4.2.2 F2 – Battery – 500mA, Anti Surge / Timed.

The battery fuse protects the ECU battery supply from overload either while charging or in standby.

4.2.3 F3 – Mains Transformer Thermal Fuse, 1A, 102°C. (Non Replaceable)

The Mains Transformer Thermal Fuse protects the ECU from overheating. The chance of this fuse blowing or breaking is very rare and highly unlikely, this circuit protection is mandatory and is non-replaceable.

4.3 Front Mounted LED's and Buttons.

4.3.1 LED's Description

The ECU has 3 front mounted status LED's to provide user feed back. The three different coloured LED's enable the user to distinguish and recognise all status conditions of the ECU and system. A Green LED shows the state of the power supply, a Red LED displays the status of call activations and the Amber LED displays the fault status of field device or power supply faults.

The LED's can operate in a number of ways to provide the user with the ECU's status and mode. The LED's can be constantly illuminated and they can also flash in a number of ways, making it easy to respond to 'Call' activations and faults.



4.3.2 LED Display Types Quick Look up Guide.

Display	Description
◦	Constantly Illuminated
⊖	Flashing Once Per Second on and Off. (1Hz)
☀	Flashing Twice Per Second on and Off. (2Hz)
⊙	Slow Blink Once Every 5 Seconds. (0.2 Hz)
⋯	Slow Flashing Once every 20 seconds. (0.05 Hz)
○	Not Illuminated Off.

4.3.3 Green LED – Power

The Green provides feedback of the state of the Mains power supply and the optional back up battery.

Action	Description
◦	<p>Constantly Illuminated</p> <p>Mains Power On The Front cover should never be removed while the mains supply is present! Shock Hazard!</p>
⊙	<p>Slow Blinking Once every 5 seconds. 0.2 Hz,</p> <p>Operating on Battery Back-Up, Mains Supply has failed or not connected. Flashing the power LED once every 5 seconds helps preserve battery charge</p>
⋯	<p>Slow Flashing Once every 20 seconds. 0.05 Hz,</p> <p>Battery Saver Auto Shutdown. When the battery falls below 10.5V the ECU automatically powers down into standby mode, no calls can be activated in "Battery Saver Mode". The Battery is Flattened</p>
○	<p>Not Illuminated Off.</p> <p>The ECU is not operating, the ECU has no mains power or the optional back up battery may be totally flat or not connected.</p>

4.3.4 Amber LED – Fault

The Amber Fault Led indicates general faults present on the system.

Action		Description
○	Not illuminated	No Fault.
●	Constantly illuminated.	General and Open Circuit Field Device Fault.
☼	Flashing twice per second. 2Hz	Short Circuit Field Device Fault.

4.3.5 Red LED – Call

The red call LED provides the user with information about the type of call activated on the system.

Action		Description
○	Not illuminated	No Call
◐	Flashing 1 Hz, Once per second	“Standard Call” Activation
☼	Flashing 2 Hz, Twice per second	“Priority Call” Activation

4.4 Front Mounted Mute / Reset / Test Button

The front mounted Mute / Reset Button has three functions. It may be used to mute the ECU (Electronic Control unit) internal buzzer during a Call or Fault, it can "Reset" a standard call activation, and it can also be used to Test the System LED's and Sounders.

4.4.1 Muting a "Standard Call"

During a "Standard Call" activation the internal Buzzer of the ECU (Electronic Control Unit) can be muted, while the buzzer is muted it will continue to produce a short bleep once every 10 seconds, as a reminder until the "Call" has been Reset. (The Field Device sounders or indicators will not be silenced).

To mute a call Press the "Mute" button momentarily (aprox. 1 Second),
The internal ECU buzzer will be muted and the field devices will continue until the ECU is reset.

4.4.2 Resetting a "Standard Call".

A "standard" call can be reset in three ways.

- 1, it can be reset from the ECU via the front mounted "Mute / Reset" button.
- 2, from a remote reset point via the front mount "Reset" button.
- 3, By an optional remote "Master Reset" point via the front mounted reset button (after first enabling the button by turning the enable key).

1, ECU "Standard Call" Reset.

Press the front mount "Mute / Reset" button for about 1 second. The System will be reset and will be returned to "Normal" quiescent stand by mode. The ECU and the system field devices will bleep twice confirming the system has returned to "Normal" stand by mode.

2, Remote "Standard Call" Reset

Press the front mount "Reset" button for about 1 second. The System will be reset and will be returned to "Normal" quiescent stand by mode. The system field devices will bleep twice confirming the system has returned to "Normal" stand by mode.

3, Remote "Master Reset"

Insert and turn the Enable key to the "Enable" position, then press the front mount "Reset" button for about 1 second. The System will be reset and will be returned to "Normal" quiescent stand by mode. The system field devices will bleep twice confirming the system has returned to "Normal" stand by mode. Remove the "Enable" key once the "Master Reset" Operation is complete.

4.4.3 System Sounder / LED Test.

The ECU can perform a basic system test, which will test the Front mounted Led, the internal buzzer and the field audible, and visual indication devices and all connecting wiring.

To begin the self test , ensure the system is in "Normal" Quiescent stand by mode, then press and hold Mute / Reset button for 3-4 seconds.





The ECU Front mounted LED's will flash in a sequence starting with the Green "Power " LED, then the Amber "Fault" LED and finally the Red "Call " LED will flash.

After first testing for the presence of an "End-of-Line" monitoring resistor and that there are no shorts on the field devices wiring the fielded devices, the system will bleep twice and the same time as the ECU internal buzzer.

After the system self-test has been completed, the Medi-tell 2 will automatically return to "Normal" stand-by mode.

4.5 Internal Piezo Buzzer

The Internal Piezo buzzer provides audible feedback to the users and engineers. There is a small cut link available to permanently silence the buzzer, this is located just to the side of the buzzer. Once this link is cut, the buzzer will not function for any event.

Action		Description
	No Sound	ECU in quiescent, working normally.
	Standard "Call"	1 Hz Pulsing Tone. On-and-Off.
	Attendant "Priority Call"	2 Hz Pulsing Tone. On-and-Off.
	Muted	Short Beep Every 10 Seconds.
	Battery Saver Auto Shut-Down	Short Beep Every 20 Seconds.

5. Installation

This section will cover the Considerations, Planning, installation and testing process, from mounting, wiring to testing of the ECU and the Field Call and Indicator Devices.

5.1 General Installation Considerations.

The positioning of all components should be given careful consideration before mounting.

Full Installation considerations / regulations can be found in BS 8300:2001

It is recommended that this system is installed to BS 8300:2001

For wiring purposes as can be seen in fig.5a the ECU is wired from one to device another in a chain, it is therefore important to ensure that the position of the ECU and field devices are positioned in such a way that the cable runs are easily from one device to another. As long as the ECU is at one end of the chain the field devices can be placed in the chain in any order.

When mounting the ECU it should be ensured that there is sufficient space for cabling, the fused spur and if fitted, the optional back-up battery unit. The fused spur or the battery back up unit can be mounted in separate/remote locations.

The ECU can supply in alarm mode a maximum of 200mA, each device will provide a load of between 12mA, and 30mA dependant on it type. To add up all the currents would be time consuming, so Ventcroft created a system known as "VEN" which stands for "Ventcroft Equivalent Number for current". VEN is very simple the ECU has a total VEN rating of 20, and when adding up the VEN ratings of the field devices it should not exceed the ECU total VEN rating. The VEN rating system is discussed in section 5.2 where all product VEN ratings are listed and some working examples are given.

Fig5a.

MEDI-TELL 2 BASIC WIRING DIAGRAM

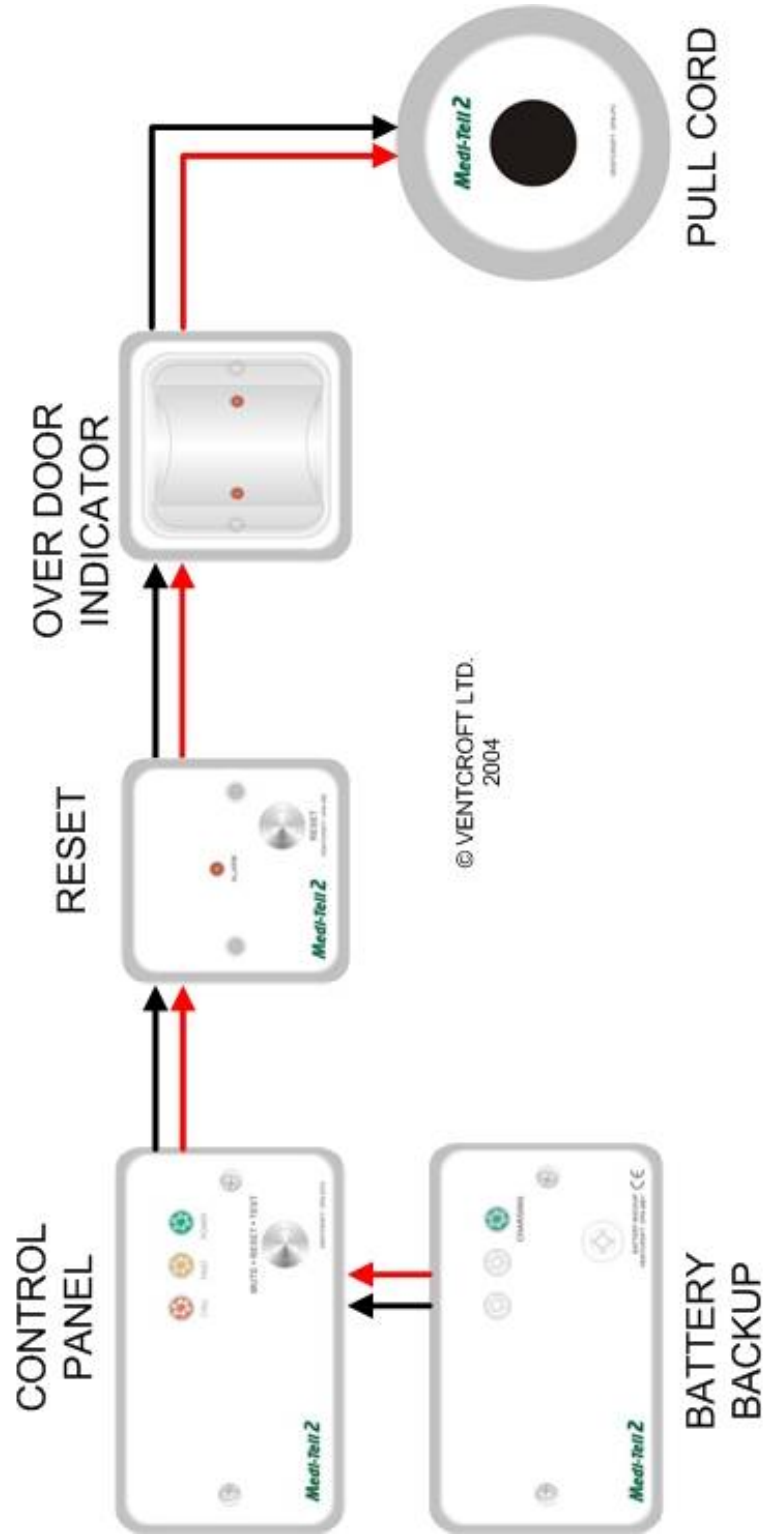

5.2 Assembly

5.2.1 Pull Cord Assembly



5.2.2 Over door Indicator

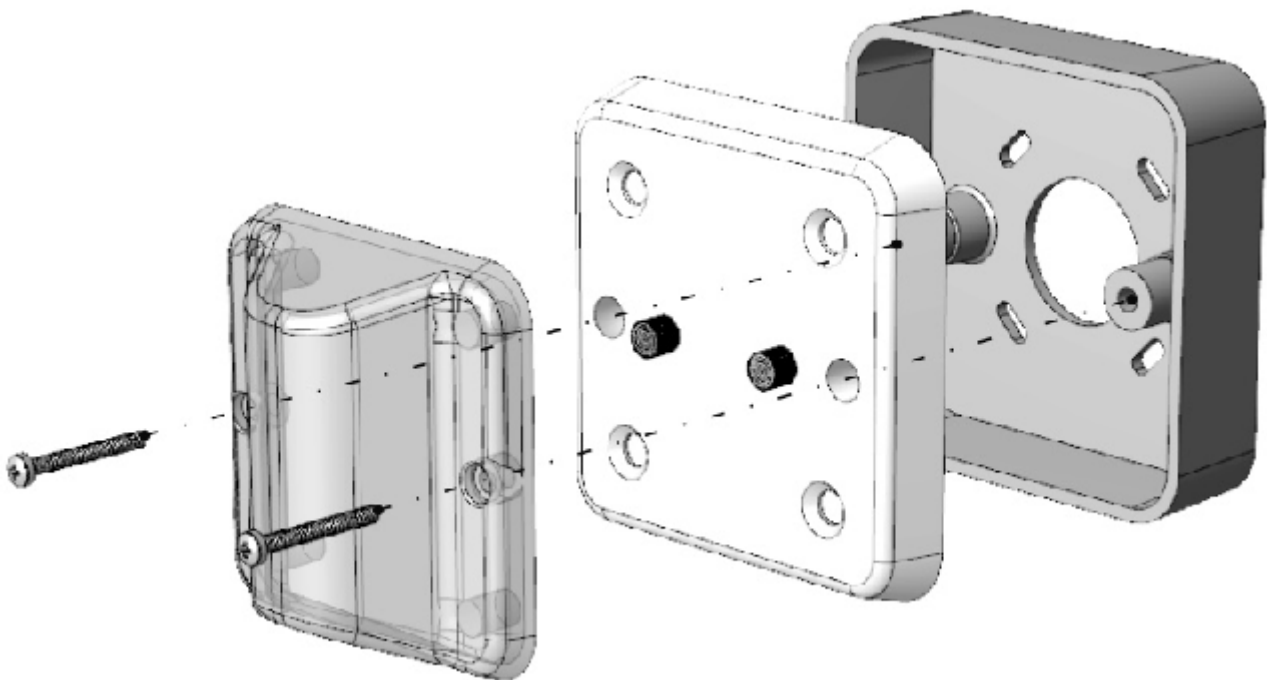

5.2.3 Reset Button

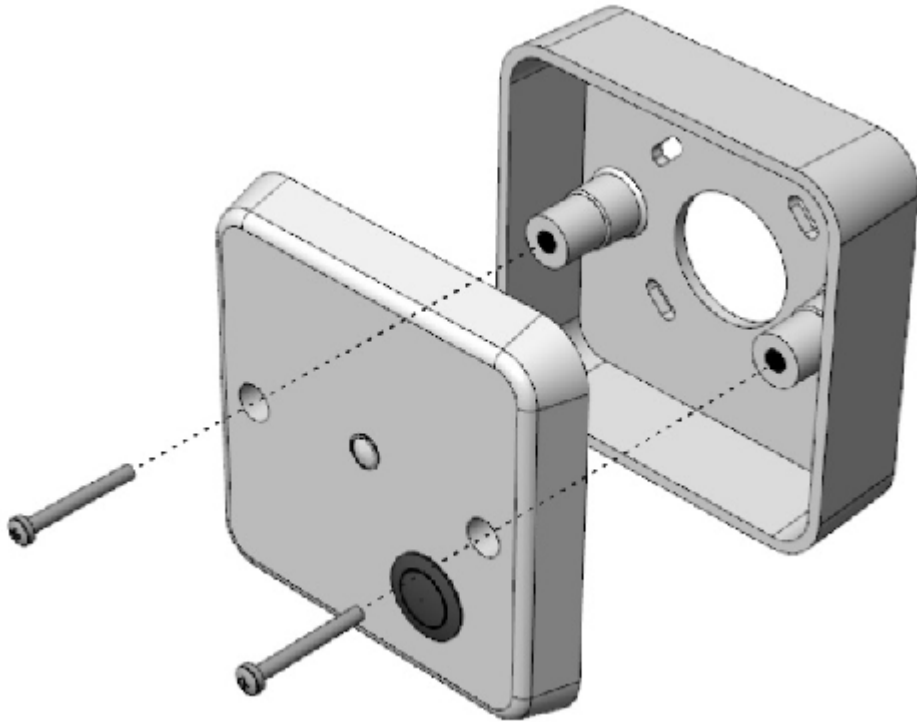

5.2.4 ECU

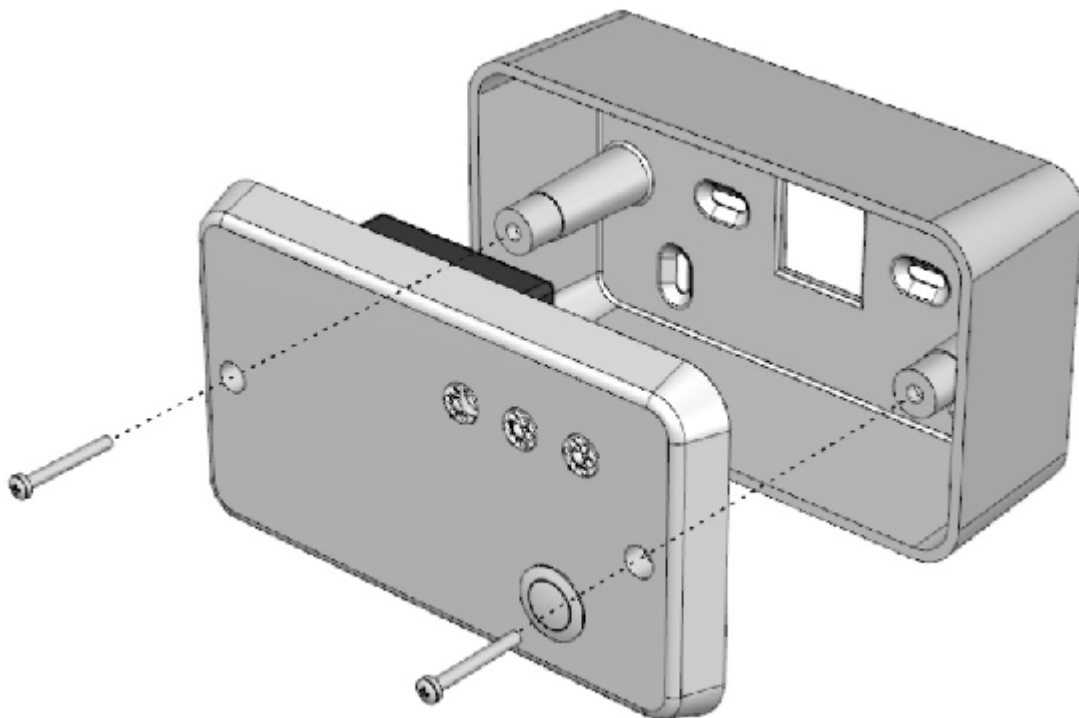

5.3 System Capacity and VEN Capacity and Ratings

The VEN "Ventcroft Equivalent Number" is a very simple system that allows engineers to calculate the number of field devices that can be connected to the ECU, Electronics Control Unit.

Each Field Device is given "VEN" Rating number, and the Control Unit that the field devices are being connected to is given a maximum VEN Load Number.

Simply plan the installation and add up all the VEN ratings of the field devices, this number is the total VEN load of the field Devices. The total VEN Load of the Field Devices must not be more than the VEN Rating of the ECU.

DPA Electronic Control Unit Total VEN Load Capacity

Description	Part Code	VEN Max. Rating
DPA Single Zone ECU	VPA-ECU	20

Individual Field Device VEN Load Ratings

Description	Part Code	VEN Load Rating
Ceiling Pull Cord.	VPA-PC	3
DPA Remote Reset	VPA-RB	2
DPA Push Button	VPA-CB	2
Over door Indicator - With Standard Sounder	VPA-ODI	4
Priority Call	VPA-DCB	2
Master Reset	VPA-DCRB	2
Banshee Sounder	FS-SSW/V	8

VEN Examples

Example		
1	1 x Ceiling Pull Cord: VEN 3 1 x Over Door Indicator: VEN 4 VEN Load	$1 \times 3 = 3$ $1 \times 4 = 4$ Total = 7
	Total VEN Capacity VEN Total Load VEN Spare	= 20 = - 7 = 13
2	2 x Ceiling Pull Cord: VEN 3 2 x Over Door Indicator: VEN 4 1 x Remote Reset: VEN 2 VEN Load	$2 \times 3 = 6$ $2 \times 4 = 8$ $1 \times 2 = 2$ Total = 16
	Total VEN Capacity VEN Total Load VEN Spare	= 20 = -16 = 4

5.4 Mounting and Fixing.

This section deals with the detail of mounting and fixing the ECU and Field devices,

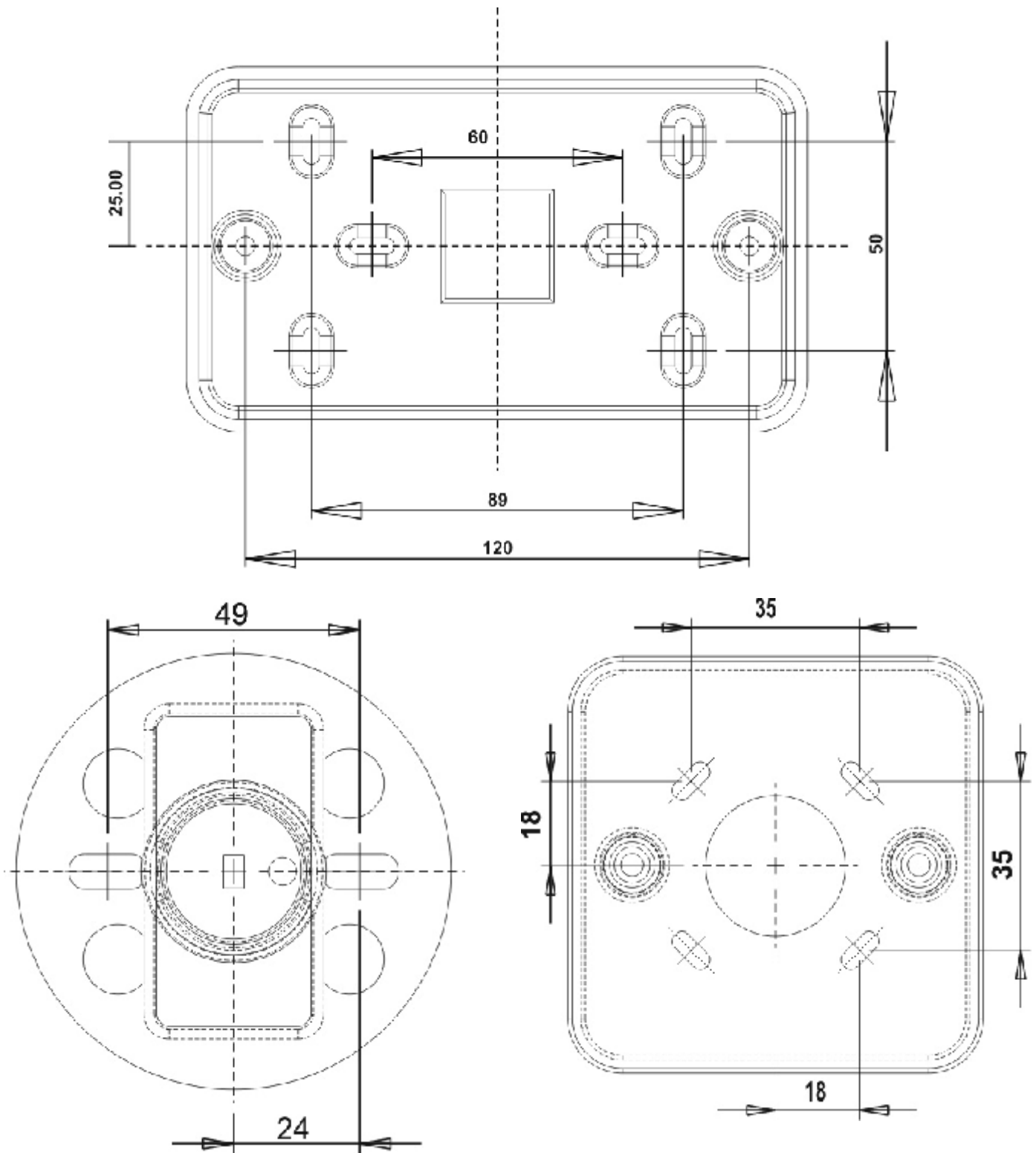

5.5 Wiring and Termination.

General Wiring and Connections

This sections deals with the wiring and connection of the ECU to the mains supply, the field devices such as the Ceiling Pull Cords, Over-Door indicators, Remote Reset Units, and the optional battery back-up battery unit.

The Medi-tell 2 system is very simple to wire, field devices are wired in 2 core cable, there are terminals in each device Marked '+ IN -' and '+OUT-' for wiring in and out to and from the next field device. The ECU requires standard mains cable to ie, 1.5mm twin and earth to wire it to the mains supply, the optional battery back-up unit requires low voltage 2 core cable.

Medi-tell 2 Electronic Control Unit, ECU.

Before making any connections ensure the mains supply is off and isolated.

1, Connect the field device cables to the "Field Device" terminal (see fig 1 Below) observe correct polarity.

2, Connect the mains supply wires, observe the correct polarity.

Note: Before making any connections ensure mains is off.

It is good practice to utilise a non-switched fused spur device between the ECU and the mains supply, fused at 1A.

3, Connect the optional back up battery unit, be sure to observe correct polarity

Do not connect any power at this point either "Mains" or "Back-Up Battery".

Field Devices, Call Points and Audible and Visual Indicators.

Wiring the field devices is very simple due to Ventcroft's "2 Wire" connection system.

Wire from the "ECU" to the first Field device and if other devices are required from the first device to the second and from the second to the third. etc.

The only observations or constraints are the connection wire polarity must be, "+" from device should be connected to "+" in the next device.

The field devices can be placed on the system in any order and can be seen in fig5a, and fig5b.

To complete the wiring and installation the "End-of-Line" monitoring resistor should be placed in the 'OUT' terminals of the very last device to complete the circuit. The end of line resistor should be a 6K8 Ω 1% 0.25W (6800 Ohms) and is supplied with the kit.

All Field devices and ECU should now be screwed up securely and the fronts fastened in place, taking care not to trap any wires.

The system is now ready for commissioning and powering up.

5.5.1 Wiring the ECU

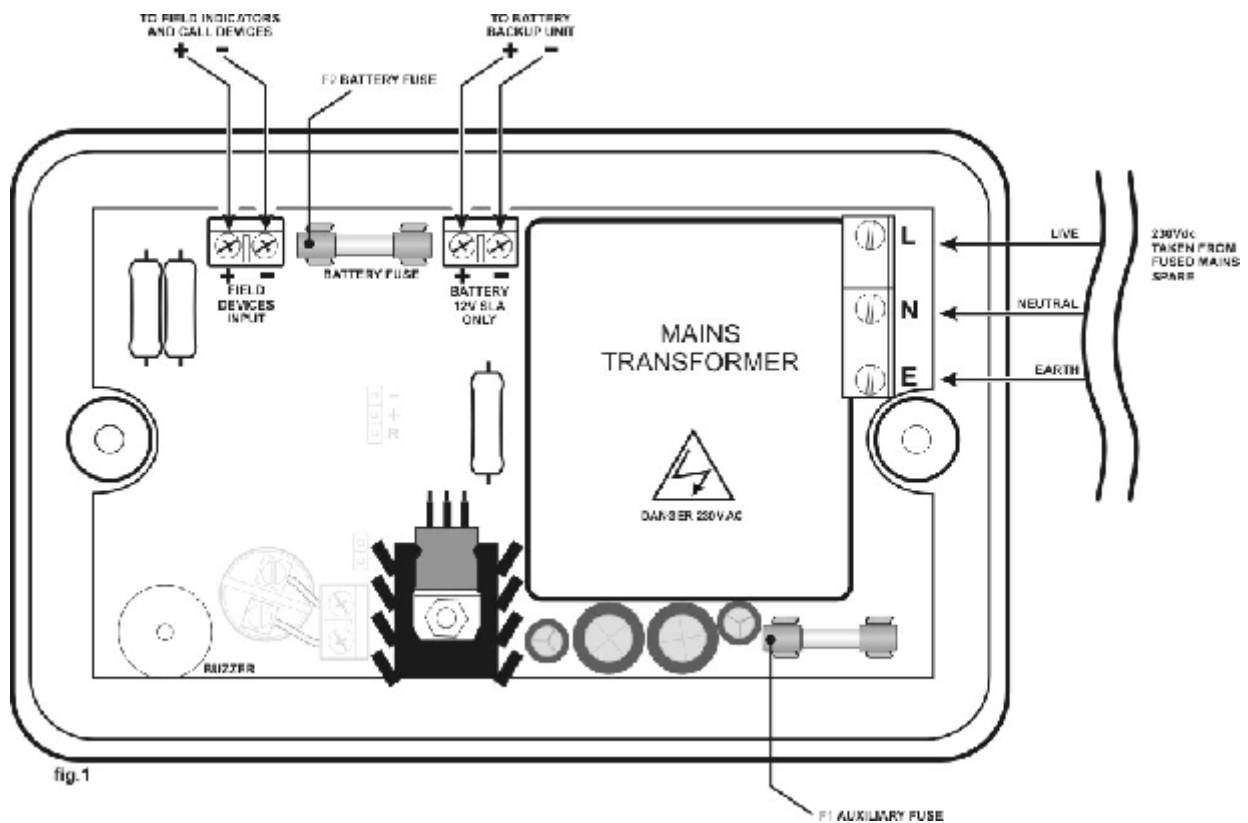

FIELD DEVICES INPUT

Field devices should be connected to the terminals as shown in Fig5a and fig5b. (the ECU is shipped with a EOL resistor already in these terminals. This resistor should be removed and placed in the 'OUT' terminals of the last device installed.)

BATTERY

An optional Battery backup unit can be connected here. Correct polarity should be observed. While Mains is present these terminals will provide a charge current to keep the backup batteries charged. When mains supply fails these terminals will supply power to the ECU.

MAINS

Note: Before making any connections ensure mains is off.

The **Mains** terminals are how the ECU receives its main power source. L terminal connects to the Live mains wire, N connects to the Neutral mains wire and E is used to connect to the mains earth wire. It is good practice to fit a Non-switched fused spur, fitted with a 1A fuses between the ECU and the mains supply. Any wiring or termination to mains supply should be in accordance to IEE regulations and installed by a trained and qualified electrician.

5.5.2 Wiring remote devices

This section sets out to ensure that the Medi-tell 2 System has been completely tested and ready to hand over for use.

Note: Remote device can be wired in any order, the End Of Line resistor (6k8) should always be placed in the last device.

MEDI-TELL 2 ADVANCED WIRING DIAGRAM

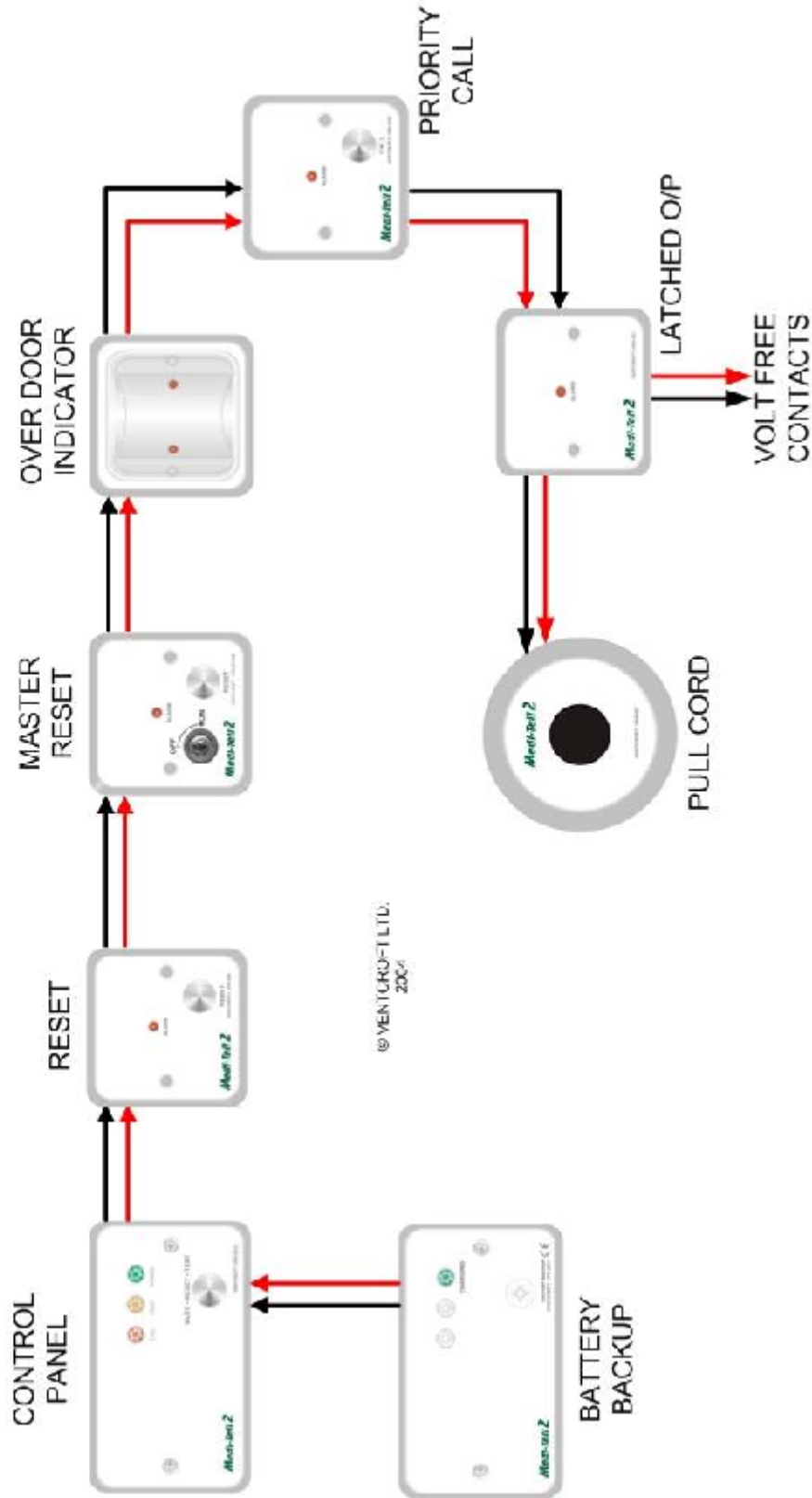

6.0 Commissioning

6.1 Powering Up.

Once the system is fully installed, the ECU and all field devices are wired up and the fronts securely fastened. The mains power can now be applied to the ECU.

1, Apply Power Mains Power, the ECU will perform a basic system test which will test the Front mounted LED's, the internal buzzer and also the field audible and visual indication devices.

The ECU Front mounted LEDs with flash in a sequence starting with the green "Power " LED, then the amber "Fault" LED and finally the red "Call " LED will flash.

After first testing for the presence of the "End-of-Line" monitoring resistor and that there are no shorts on the field devices wiring the field devices will bleep twice and the same time as the ECU internal buzzer.

After the system self-test has been completed, the 'Medi-tell 2' will return to "Normal" stand-by mode.

7.0 Operation and Functionality

This section sets out to detail the operation and functionality of the Medi-tell 2 system. Including the different operation modes and how to "Activate" and "Reset" the standard "Call" and attendant "Priority Call" Alarms, how to use the ECU mute facility, battery back up mode and "Battery Saver Sleep".

7.1 Normal Quiescent Mode.

Normal Quiescent mode is when the DPA system is in standby and waiting to receive a "Call" or a "Priority Call" from one of the field devices.

In "Normal Quiescent" mode the ECU has mains power supplied to it and the Green power LED is illuminated.

7.2 Call Mode.

"Call" mode is when a "Call" Device is activated ie, by pulling a Ceiling Pull Cord Call Point (VPA-PC), or pressing the Push Button Call Point, (VPA-CB).

To generate a "Call" and summon a response, activate a call device, ie pull the Ceiling Pull-Cord Call Point

The Red "Call" LED on the DPA ECU will begin to flash in sympathy with the field Indicator devices, some field devices have built in sounders which will be sounding in sympathy with the visual indicators.

7.3 Mute A Call at the DPA ECU.

During a "Standard Call" activation it is possible to mute the ECU internal sounder. This could be desirable if the ECU is mounted in an location where noise my be a nuisance. If the DPA is muted the internal buzzer will be muted, but the field devices will continue until the system is "Reset".

To mute the ECU internal sounder during a call activation press the "Mute / Reset " button on the ECU (see Fig 1) the internal buzzer will then be "muted" . The internal sounder will be muted and then only produce a very short bleep once every 10 seconds. The Field Devices will continue in alarm until the system is reset.

Note: Only a standard "Call" And general Fault can be muted.

"Priority call", "Mains Fail", "Battery Saver" cannot be muted.

7.4 Reset A Call.

A system "Call" can be reset in several ways, either from the ECU it self, a Remote Reset Point or from a Key Enabled Master Reset Point.

7.4.1 From the ECU.

The ECU has a front mounted "Mute / Reset " button which can be used to reset Medi-tell 2 System.

To reset a "Call" activation press and hold the "Mute / Reset " button for approximately 1 second. The call activation will be cleared and the Medi-tell 2 system will return to its quiescent state.

7.4.2 From a Remote Reset Point

To "Reset" a system "Call" from a "Remote Reset Point" simply press the "Reset" button momentarily (around 0.25 of a second). Once the Reset button has been pressed the Field device indicators will illuminate and the field sounders will produce 2 short bleeps to confirm a positive system reset action.

7.4.3 From A Master Reset Point

The "Master Reset Point" is used to either to Reset a "Priority Call" or a standard "Call", the master reset has a front mounted key switch and a push button. The keys switch provides security, the reset button can not "Reset" the system unless the key switch has been activated.

Insert the master reset key into the master reset point and turn it clock wise over 90 degrees, then simply press the "Reset" button momentarily (around 0.25 of a second). Once the Reset button has been pressed the Field device indicators will illuminate and the field sounders will be make 2 short bleeps confirmation a positive system reset action.

7.5 Attendant "Priority Call" Mode.

The Attendant "Priority Call" is similar to a standard "Call" but the speed of the field device indicators and sounders are activated is twice as fast (around 2 Hz or twice per second).

An attendant "Priority Call" can be generated either from "Normal Quiescent Standby" or while a standard "Call" is in progress.

The Attendant "Priority call" device is an optional extra and can be either purchased in a kit which includes a "Master Reset" point part code; VPA-DCBM, or it can be purchased separately, part code, VPA-DCB.

7.5.1 Attendant "Priority Call" From "Normal Quiescent" mode.

To generate an attendant "Priority Call" and summon a response , actuate a "Priority Call" device, ie Surface / Flush Mounting Call Button (VPA-CB)

On actuating the Priority call device the Red "Call" LED on the ECU will begin to flash rapidly (around 2Hz, Twice per second) in sympathy with the field Indicator devices, some field devices have built in sounder which will be sounding in sympathy with the visual indicators

The "Priority Call" device on board LED will also flash in sympathy with the visual and audible indicators.

7.5.2 During a Standard "Call" Activation.

A "Priority Call",

To generate a "Priority Call" and summon a response, actuate a "Priority Call" device, ie Surface / Flush Mounting Call Button (VPA-CB)

On activating the Priority call device the Red "Call" LED on the ECU will begin to flash rapidly (around 2Hz, Twice per second) in sympathy with the field Indicator devices, some field devices have built in sounder which will be sounding in sympathy with the visual indicators

The "Priority Call" device on board LED will also flash in sympathy with the visual and audible indicators.

7.6 Master Reset a "Priority Call" or a "Call"

The "Master Reset Point" is used to either reset a "Priority Call" or a standard "Call", the master reset has a front mounted key switch and a push button. The keys switch provides security, the reset button can not "Reset" the system unless the key switch has been activated.

Insert the master reset key into the master reset point and turn it clock wise over 90 degrees, then simply press the "Reset" button momentarily (around 0.25 of a second). Once the Reset button has been pressed the Field device indicators will illuminate and the field sounders will be produce 2 short bleeps to confirmation a positive system reset action.

7.7 Battery Back-Up Standby By Mode.

Should the mains fail and an optional Battery Back-up Unit is connected to the system then the ECU will continue to function on a battery supply.

When operating on "Battery Back-Up" the green "Power" LED with flash once every 5 seconds. The Internal buzzer will bleep once every 5 seconds.

Once mains power is reapplied the green "Power" LED will return being constantly illuminated.

It may take up to five seconds for the "Power" LED to change from either constant to flashing or flashing to constant while the ECU adjust to the changing voltages.

7.8 Battery Saver Auto Shut Down.

"Battery Saver" Auto Shut Down is a mode which protects the optional back-up battery when the battery become excessively flattened. When a battery drops below a critical voltage (charge) it is possible to damage a battery beyond repair, this is known as deep discharge.

When the Back-Up Battery falls below 10.5Vdc the ECU automatically shuts down all functions of the Medi-tell 2 system, the Field devices will not function.

When in "Battery Saver" Auto Shut Down mode green "Power" LED with flasher once every 20 seconds. The Internal buzzer will bleep once 20 Seconds..

8.0 Maintenance and Regular Testing

This section details the regular and necessary testing and inspection of the Medi-tell 2 system. Its is just as important to provide regular testing and maintenance of the system as it is to install the system correctly.

8.1 Regular System Testing.

The entire system is to be tested regularly to ensure the system is always ready for use. The testing is simple;

1. activate the first call device.
2. activate the first reset device.
3. continue until all call and reset devices have been tested.

A simple test can be done by holding down the Mute/Reset/Test Button for approx 3 seconds. The system will reset and run its power-up self diagnosis start-up sequence. This will test for cable continuity and will power all devices on the system to check for short circuits and faulty devices.







It is recommended that the whole system be tested a minimum of at least once per month, but it is desirable to fully test or part test the system on a weekly basis.



8.2 Battery Replacement.

Re-chargeable batteries need regular maintenance and replacement.

It is recommended that Sealed lead acid batteries (SLA) are replaced once every 3-4 years to provide reliable and consistent operation of the VPA during a mains failure.

9.0 Accessories and Spare Parts

	Surface Mount Call response control unit, with three status LED's, internal buzzer, mute / reset button. 230 Vac mains input, and battery back up option, Quiescent Current 18mA. Max. Zone O/P Current 200mA. 373g.	VPA-ECU
	Battery Backup 250 mAh unit, battery charge LED, surface mounting. 6 Hours Standby Time (approx) . Sold c/w with 1 Rechargeable 250 mAHr Ni-Cd Battery. Can be expanded to up-to 4 batteries providing 1 Ahr capacity and extra stand-by and alarm time during mains failure	VPA-BB1
	Surface mount "DPA" Pull Cord Call Device, complete with pull cord actuator, indicator LED, Internal Peizo Buzzer with disable buzzer cut link, and 2 hand pull anchors. 72g. Activated Current 20mA.	VPA-PC
	Surface Mount Over Door Indicator, with internal buzzer with disable buzzer cut link and twin red LED illumination.130g. Activated Current 30mA.	VPA-ODI
	Surface Mount Remote "DPA Remote Reset Push Button", with indicator LED. 117g. Activated Current 12mA.	VPA-RB
	Surface Mount Remote Interface Device. Provides Voltage free contacts, when an alarm is activated the voltage free contacts close and allow the stand alone VPA system to be interfaced easily with building management systems or other warning devices. Max contact Current 300mA	VPA-ID1
	Spare adhesive disabled Sign. Sold in 1's and 10's	VPA-DS1 VPA-DS10

	Surface Mounting Remote "DPA Push Button", with indicator LED. 117g. Activated Current 12mA.	VPA-CB
	Spare Surface Mounting Double Gang Deep back Box for DPA-ECU	VPA-DG
	Spare Single Gang Low Profile Surface Mounting back Box for VPA-ODI, VPA-RB AND VPA-ID1	VPA-SG
	Surface Mounting "Priority Call Push Button" response Device.117g. Activated Current 12mA. - Must be reset by "Attendant Distress Master Reset Device"	VPA-DCB
	Surface Mounting "Auxiliary Sounder 9-30V" 30mA, Slim base.	VFS-SSW/V
	Surface Mounting "Auxiliary Sounder 9-30V" 30mA, Deep base.	VFS-SSWPW/V
	Surface Mounting "Attendant Distress Master Reset Device" push button with key enable, reset button and call LED, 150g. Activated Current 12mA.	VPA-DCRB

10.0 Specifications

10.1 Ceiling Mount Call Pull Cord

Detailed Specifications			
Power Supply	Input Voltage		12Vdc
	Quiescent Standby Current		0mA
	Maximum Current During Alarm		20 mA dc (Max.)
Weights and Measures	Product Dimensions	Dimensions	80*80*50 (L*W*H)
		Weight	55g
	Packaging	Dimensions	80*80*50 (L*W*H)
		Weight	60g
		Bulk Pack QTY.	10
User Operation	Pull Cord		Response alarm
LED	Front Mounted	Alarm / Call - Amber	Illuminates in sympathy with system
Buzzer	Internal Buzzer with cut link		75dB @ 30cm
VEN Rating			VEN 2
Termination			2 Wire in 2 Wire Out
Housings	Material	ABS	
	Colour	White	
PCB	Ident	PCB45.2 - A1	
Compliance	European	CE	
	Ingression Protection Rating.	IP20	
Re-Ordering	Pull Cord	VPA-PC	
Warranty	Period	2 Years from date of Manufacture	
	Identification	Date of Manufacture Marked On PCB	

10.2 Surface / Flush Mount Remote Reset.

Detailed Specifications			
Power Supply	Input Voltage		12Vdc
	Quiescent Standby Current		0mA
	Maximum Current During Alarm		15 mA dc (Max.)
Weights and Measures	Product Dimensions	Dimensions	80* 80*30(L*W*H)
		Weight	g
	Packaging	Dimensions	80*80*50 (L*W*H)
		Weight	g
		Bulk Pack QTY.	10
User Operation	Remote reset Button		Response alarm
LED	Front Mounted	Alarm / Call - Amber	Illuminates in sympathy with system
VEN Rating			VEN 2
Termination			2 Wire in 2 Wire Out
Housings	Material	ABS	
	Colour	White	
PCB	Ident	PCB45.2 - B1	
Compliance	European	CE	
	Ingression Protection Rating.	IP20	
Re-Ordering	Remote reset Button	VPA-RB	
Warranty	Period	2 Years from date of Manufacture	
	Identification	Date of Manufacture Marked On PCB	

10.3 Surface / Flush Mount Over Door Indicator.

Detailed Specifications

Power Supply	Input Voltage		12Vdc
	Quiescent Standby Current		0mA
	Maximum Current During Alarm		30 mA dc (Max.)
Weights and Measures	Product Dimensions	Dimensions	80*80*55 (L*W*H)
		Weight	g
	Packaging	Dimensions	80*80*50 (L*W*H)
		Weight	g
		Bulk Pack QTY.	10
User Operation	Remote reset Button		Response alarm
LED	Front Mounted	Alarm / Call - Amber	Illuminates in sympathy with system
Buzzer	Internal buzzer with cut link		75dB @ 30cm
VEN Rating			VEN 4
Termination			2 Wire in 2 Wire Out
Housings	Material		ABS
	Colour		White
PCB	Ident		PCB45.2 - C1
Compliance	European		CE
	Ingression Protection Rating.		IP20
Re-Ordering	Over Door indicator		VPA-ODI
Warranty	Period		2 Years from date of Manufacture
	Identification		Date of Manufacture Marked On PCB

10.4 Surface / Flush Mount Interface Device.

Detailed Specifications

Power Supply	Input Voltage		12Vdc
	Quiescent Standby Current		0mA
	Maximum Current During Alarm		15 mA dc (Max.)
Weights and Measures	Product Dimensions	Dimensions	80*80*30 (L*W*H)
		Weight	g
	Packaging	Dimensions	80*80*50* (L*W*H)
		Weight	g
		Bulk Pack QTY.	10
User Operation	Remote reset Button		Response alarm
LED	Front Mounted	Alarm / Call - Amber	Illuminates in sympathy with system
Contacts	Volt Free contacts (Opto-Isolator)		300mA @ 30Vdc
VEN Rating			VEN 2
Termination			2 Wire in 2 Wire Out
Housings	Material		ABS
	Colour		White
PCB	Ident		PCB53.01
Compliance	European		CE
	Ingression Protection Rating.		IP20
Re-Ordering	Over Door indicator		VPA-ID1
Warranty	Period		2 Years from date of Manufacture
	Identification		Date of Manufacture Marked On PCB

10.5 Battery Backup Device.

Detailed Specifications			
Power Supply	Input / Output Voltage		13.8Vdc / 11.5Vdc
	Quiescent Standby Current		5mA
	Maximum Discharge Current		200 mA dc (Max.)
Weights and Measures	Product Dimensions	Dimensions	140*80*40 (L*W*H)
		Weight	g
	Packaging	Dimensions	325*195*75 (L*W*H)
		Weight	g
		Bulk Pack QTY.	10
User Operation	Battery backup		Secondary Power supply
LED	Front Mounted	Charging - Green	Illuminates when Battery is charging.
Contacts	Contacts available for up to 4 batteries.		
VEN Rating			N/A
Termination	2 Wire in/out		
Housings	Material		ABS
	Colour		White
PCB	Ident		PCB47.1
Compliance	European		CE
	Ingression Protection Rating.		IP20
Re-Ordering	Battery Backup		VPA-BB1
Warranty	Period		2 Years from date of Manufacture
	Identification		Date of Manufacture Marked On PCB

10.6 Priority Call Button.

Detailed Specifications			
Power Supply	Input Voltage		12Vdc
	Quiescent Standby Current		0mA
	Maximum Current During Alarm		15 mA dc (Max.)
Weights and Measures	Product Dimensions	Dimensions	80*08*30 (L*W*H)
		Weight	g
	Packaging	Dimensions	80*80*50 (L*W*H)
		Weight	g
		Bulk Pack QTY.	10
User Operation	Priority Call Button		Response alarm
LED	Front Mounted	Alarm / Call - Amber	Illuminates in sympathy with system
VEN Rating			VEN 2
Termination	2 Wire in 2 Wire Out		
Housings	Material		ABS
	Colour		White
PCB	Ident		PCB45.x
Compliance	European		CE
	Ingression Protection Rating.		IP20
Re-Ordering	Over Door indicator		VPA-DCB
Warranty	Period		2 Years from date of Manufacture
	Identification		Date of Manufacture Marked On PCB

10.7 Master Reset Button.

Detailed Specifications

Power Supply	Input Voltage		12Vdc
	Quiescent Standby Current		0mA
	Maximum Current During Alarm		15 mA dc (Max.)
Weights and Measures	Product Dimensions	Dimensions	80*80*30 (L*W*H)
		Weight	g
	Packaging	Dimensions	80*80*50 (L*W*H)
		Weight	g
		Bulk Pack QTY.	10
User Operation	Master Reset Button		Response alarm
LED	Front Mounted	Alarm / Call - Amber	Illuminates in sympathy with system
Contacts	Key-switch enable (2 keys included)		
VEN Rating			VEN 2
Termination			2 Wire in 2 Wire Out
Housings	Material		ABS
	Colour		White
PCB	Ident		PCB45.x
Compliance	European		CE
	Ingression Protection Rating.		IP20
Re-Ordering	Master Reset Button		VPA-DCRB
Warranty	Period		2 Years from date of Manufacture
	Identification		Date of Manufacture Marked On PCB

10.8 Surface / Flush Mount Electronic Control Unit - ECU.

Detailed Specifications

Power Supply	Mains Input Voltage		230Vac 50Hz	
	Transformer Primary Thermal Fuse		1A 102 DEG C. (Non Replaceable))	
	Quiescent Standby Current		16mA dc (Buzzer Muted)	
	Maximum Overall Supply Current		250 mA dc (Max.)	
	Fault Current with Buzzer		26mA	
User Operation	Button	In Call	Press 0.5 Seconds	Mute
	Front Mounted	In Muted Call	Press 2 Seconds	Reset
		In Priority	N/A	Disabled
		In Quiescent	Press 3 Seconds	Master Reset / Test
LED's	Front Mounted	Mains - Green	Mains On	Constant: Mains Present
		Call - Red	Battery Back Up	Pulse Every 5 Seconds
			Battery Saver	Pulse Every 20 Seconds
			Standard	Slow Flashing - 1.Hz
			Priority	Rapid Flashing - 2 Hz
Fault - Yellow	Open Circuit	Constant		
	Short Circuit:	Flashing - 1 Hz		
Internal Buzzer	Type		Peizo, PCB Mounted 75dB @ 30cm	
	Current		5mA max.	
	Frequency		1 Khz Tone	
	Sounds	Call	1 Hz Pulse	
		Priority	2 hz Pulse	
		Mute	Beep Every 10 Seconds	
		Battery Saver	Beep Every 20 Seconds	
		Enter Battery Saver	10 Quick Beeps	
Mains Re-Applied	5 Quick Beeps			
Field Device Inputs	Number of Zone Circuits		1	
	Detection Supply		Voltage	12 Vdc +/- 10%
			Max Current	25mA
			Protection	Shut Down at 25mA
	Detection Mode Monitoring		Short Circuit	> 25mA
			Open Circuit	< 1.5mA
			Call	<=> 4.5mA
			Call Reset	<=> 4.5mA / Reverse Short
			Priority Call	<=> 3mA
			Master Reset	<=> 3mA / Reverse Short
			End of Line	<=> 1.2mA
Field Device Outputs	Number of Zone Circuits		1	
	Sounder Supply		Voltage	12 Vdc +/- 10%
			Max Current	200mA
			Protection	Shut Down at 200mA
	Alarm		Call	1 Hz Pulse
			Priority	2 Hz Pulse
			Fault Cleared	2 Quick Pulses
		Reset	2 Pulses	
		Master Reset	2 Pulses	
VEN Load Rating			VEN20	
Battery Input	Charging Voltage		13.8 Vdc	
	Deep Discharge Protection		Less than 10.5Vdc	
Fuses	F1: Auxiliary		500mA Anti Surge 20mm Glass	
	F2: Battery		500mA Anti Surge 20mm Glass	
	F3: Mains Transformer Thermal Fuse		1A 102 deg. C (non replaceable)	
Housing	Front Cover		ABS - White	
	Back Box			
Compliance	European		CE	
	Ingression Protection Rating.		IP20	
Re-Ordering	Control Unit		DPA-ECU	
Warranty	Period		2 Years from date of Manufacture	
	Identification		Date of Manufacture Marked On PCB	
Last Updated			17.08.05	

NOTES:

If you have a questions about this product please do not hesitate to ring,
Technical Help : +44 (0)1928 581098

Ventcroft Ltd
Goddard Road
Astmoor Industrial Estate
Runcorn, Cheshire,
WA7 1NQ, United Kingdom
Tel: +44 (0)1928 581098
Fax: +44 (0)1028 581099
Email: sales@ventcroft.co.uk
Web: www.ventcroft.co.uk