

FIRETRAX™

FT6EN/T

FIRE DETECTION PANEL

Designed to Comply with BS5839 part 4 1988



FT6EN/T

This manual should be left with the panel after installation.

Ventcroft Ltd.
Goddard Road,
Astmoor, Runcorn,
Cheshire WA7 1NQ,
Great Britain.
Phone: 01928 581098
Fax: 01928 581099
E-Mail: info@ventcroft.co.uk
<http://www.ventcroft.co.uk>



Manufacturing Global Security in Great Britain....with Pride

Introduction

The information provided in this manual covers the Firetrax FT6EN/T fire alarm control panels. The Firetrax range is designed to meet the requirements of EN54 Parts 2 & 4.

This product should be installed, commissioned and maintained by suitably qualified service personnel with reference to IEE regulations and any statutory requirements.

General Description

The Firetrax range of fire alarm control panels are microprocessor controlled and are available with either 2, 4 or 6 sense zones (detector zones) dependent on the model. Both panels in the Firetrax 1-2 range have 2 alarm zones (bell zones), zone disable facility, fault output and one set of volt free changeover contacts which operate on fire. The Firetrax FT6EN/T range has all the above features plus one man test, class change input, non-latching facility, an extra set of volt free changeover contacts and a 28V output that is energised on fire.

Installation Procedure

Before proceeding with the installation, please read the section *Panel Operation*.

Installation of the panel should be carried out by qualified personnel.

Using the metal box as a template, mark the position of the fixing holes on the wall. Drill and plug the wall, then screw the panel to the wall. Ensure the panel is free from knockout discs, swarf and other debris.

Do not remove any end of line resistors from the panel until after the following test is performed.

With all end of line resistors fitted inside the panel, connect the panel mains supply to an exclusive 240V AC fused supply. Switch the mains supply on. The internal buzzer will sound. Connect two sealed lead acid batteries to the panel - they should be connected in series providing a 24V DC supply.

With both the mains and battery supplies connected, the panel should be silent and in its normal operating mode (power lamp on, alarms & buzzer silent). **If a fault is indicated, refer to the fault finding section before proceeding.** Disconnect the batteries and switch off the mains supply.

Remove the 3k3 end of line resistor from sense zone 1. Terminate sense zone 1 circuit wiring in the panel observing correct polarity and fit the end of line resistor at the very end of the circuit. Check that all the detectors and call points are correctly wired. With sense zone 1 connected and all other end of line resistors fitted inside the panel, connect the mains and battery supplies. **If the panel indicates a fault, refer to the fault finding section before proceeding.** Do not megger cables connected to either the panel or any field devices. If no faults are indicated then power down the panel and follow the same procedure with the additional sense zones and then the alarm zones. Adding the zones one at a time makes fault finding and commissioning much simpler. Make sure that no bare wires come into contact with the panel circuit boards during installation.

Detector Head Removal

The Firetrax FT6EN/T range supports head removal. The basic principle of head removal is to ensure that all call points will function even if a detector head has been removed. Head removal requires either zener clamp bases or schottky diode bases with the appropriate end of line device to be fitted. When a detector head is removed, the panel will show a fault, but the sense zone circuit will remain intact. Consult the table on page 10 for further information.

Panel Operation

Enabling the front panel buttons.

To enable the front panel buttons, the key switch in the top left of the panel must be turned to the 'On' position.

Performing a lamp test.

If the panel is in its normal condition, pressing the Reset button will cause the panel to perform a lamp test.

Resetting the panel after a fire is detected.

To reset the panel after a fire event, press the Silence button followed by the Reset button.

Resetting the panel.

If any of the panel functions have been activated, pressing the Reset button will return the panel to its normal condition.

Silencing/resounding the alarms.

If a fire is detected, the panel will automatically activate the alarm circuits. To silence the alarms, press the Silence button once. To resound the alarms, press the Silence button again.

Silencing the internal buzzer.

If a fault is detected by the panel, the internal buzzer will sound. To silence the buzzer press the Silence button.

Using the one man test function (Firetrax FT6EN/T only).

To enter test mode, press the Test button. The test LED will be lit and zone 1 fault LED will be flashing. To place zone 1 into test mode, press the Silence button. Press the Test button again and now zone 2 fault LED will be flashing with zone 1 fault LED on steady if it is in test mode. To select further zones, press the Test button to cycle through the zones and use the Silence button to toggle the status of the selected zone. Placing too many zones into test mode at the same time may leave the building with inadequate protection.

When a zone in test mode detects a fire event, the alarms will ring for a few seconds before resetting. If the panel is left in test mode and no events occur for approximately 10 minutes, the panel will automatically exit test mode and resume normal operation.

If a fire is detected on a zone not in test, then the panel will enter the fire condition and exit test mode.

To exit test mode and return the panel to normal operation, press the Reset button.

Using the disable function.

The panel allows the user to selectively disable the sense zones and the alarm zones. The selection process is very similar to that used in the test function. To enter disable mode, press the Disable button. The disable LED will be lit and zone 1 disable LED will be flashing. Pressing the Silence button will toggle the status of the selected zone and pressing the Disable button will cycle through the available zones.

Once the required zones have been selected, press the Reset button. If any zones were disabled, the disable LED and the relevant zone disable LED(s) will remain lit. All incoming signals from disabled sense zones will be ignored. **If the alarm zones are disabled, then the alarms will not be activated even if the panel detects a fire event on an active sense zone.**

Selecting a zone as non-latching (Firetrax FT6EN/T+ only).

In some situations, such as interlinking fire alarm panels, it is necessary to set a sense zone as non-latching. When a fire event is detected on a non-latching zone, the panel will go into fire as usual but will automatically reset as soon as the device signalling fire is reset.

To enter the non-latching selection mode, press and hold down the Test button. While still holding the Test button, momentarily press the CPU RESET button inside the panel, followed by the WATCHDOG RESET (W/D) button. Keep the Test button held down until the disable and general fault LEDs light, then release the Test button. Zone 1 fault and disable LEDs will be flashing. Pressing the Silence button will toggle the status of the selected zone and pressing the Test button will cycle through the available zones. After the relevant zones have been selected, press the Reset button.

Fault Finding

Front panel buttons not working.

To activate the front panel buttons, turn the keyswitch in the top left of the panel to the ON position.

Fault LED and sense zone fault LED flashing, buzzer sounding.

Faults monitored are:

- Open circuit on the sense zone wiring.
- Short circuit on the sense zone wiring.
- Detector head removal.

Check all detectors and call points on the sense zone indicated. Check wiring is as in example diagrams and ensure the end of line monitor is a 3k3 resistor or an active end of line device.

Fault LED and alarm zone fault LED flashing, buzzer sounding.

Faults monitored are:

- Open circuit on the alarm zone wiring.
- Short circuit on the alarm zone wiring.
- Blown alarm fuse(s) - Note that on the Firetrax FT6EN/T+, drawing excessive current from the 28V Aux supply will blow the fuse in Alarm Zone 2.

Check alarm zone wiring is as in example diagrams and ensure that the 10k end of line resistor is fitted. Check alarm zone fuses.

Fault LED and PSU Fault LED flashing, buzzer sounding.

Faults monitored are:

- Battery supply not present.
- Batteries damaged or not fully charged.
- Blown battery fuse.
- Mains supply not present.
- Blown mains fuse.

Check relevant fuses. Ensure batteries are connected correctly and battery leads are secure.

Fault LED and Earth Fault LED flashing, buzzer sounding.

The panel has detected an earth fault. The only earth connection to the panel terminals should be to the mains input terminal block. Check that no other earth connections are present.

Fault LED and CPU fault LED lit.

Processor fault detected. If no other problems are found then reset the processor. Inside the panel are two push buttons marked CPU RESET and WATCHDOG RESET (W/D). Press CPU RESET followed by WATCHDOG RESET (W/D).

Panel does not indicate fire when a call point or detector is tested.

Either a faulty call point/detector or wiring not as shown in diagrams. Check the firing resistance of the device is 510 ± 200 ohms and ensure that the correct end of line device is fitted.

Head removal not working.

Check compatible base is being used and is wired correctly. Either a zener clamp base with a 3k3 end of line resistor, or a schottky diode base with an active end of line device must be used.

Power LED blinks intermittently

This is perfectly normal and indicates that the processor is running an internal memory check.

Fuse ratings.

Mains fuse 1A A/S

Alarm fuses 200mA A/S for Firetrax FT6EN/T, 300mA A/S for Firetrax FT6EN/T

Battery fuse 1A A/S for Firetrax FT6EN/T, 2A A/S for Firetrax FT6EN/T

Fault output.

The auxiliary fault output, marked AF on the PCB, is an open collector output that is normally pulled low. When the panel detects a fault, the AF output is switched into its high impedance state. Refer to the wiring diagram on page 13 for example connection details.

Other faults.

For any other faults, perform a CPU reset. Inside the panel are two push buttons marked CPU RESET and WATCHDOG RESET (W/D). Press CPU RESET followed by WATCHDOG RESET (W/D). This will restart the processor, but all configuration information (disable, non-latching) will have to be re-entered.

Panel Specifications

	Saffire 1	Saffire 2
Mains Voltage (V AC)	240	240
System Voltage (V DC)	28.4	28.4
Quiescent Current (mA)	65	65
Quiescent Current, Unsilenced Fault (mA)	75	75
Minimum Battery Size 2 x 12V Required (Ah)	2.2	2.2
Detector Voltage (V DC)	20	20
Number of Sense Zones	1	2
Maximum Number of Detectors per Zone	30	30
Firing Resistance (Ohms)	510 ±200	510 ±200
Sense Zone End of Line (Ohms)	3k3	3k3
Alarm Voltage (V DC)	28.4	28.4
Number of Alarm Zones	2	2
Maximum Alarm Current per Zone (mA)	200	200
Maximum Number of Sounders per Zone	10	10
Alarm Zone End of Line (Ohms)	10k	10k
Max. Auxiliary Supply Current in Fire (mA)	-	-
Panel Weight Including Batteries (kg)	4.5	4.5
Panel Dimensions (mm)	234 x 225 x 85	234 x 225 x 85

Saffire+2	Saffire+4	Saffire+6
240	240	240
28.4	28.4	28.4
95	95	95
99	99	99
3	3	3
20	20	20
2	4	6
30	30	30
510± 200	510± 200	510± 200
3k3	3k3	3k3
28.4	28.4	28.4
2	2	2
300	300	300
16	16	16
10k	10k	10k
50‡	50‡	50‡
5	5	5
285 x 230 x 85	285 x 230 x 85	285 x 230 x 85

‡ The 28V Aux supply is derived from Alarm Zone 2. This must be taken into account when calculating the alarm current.

Detector Base and Call Point Wiring Information

Part Number	Terofire STB-4SDR	Hochiki YBK-R/5ZD	Hochiki YBN-R/4	Apollo S60 Diode Base	Apollo S60 Common Base	KAC Call Point	Fullon Call Point	Resettable Call Point
Positive In	4	L1	2	L1 IN	L1 IN	1	470 Ohms	+ IN
Positive Out	4	L2	1	L1 OUT	L1 OUT	1	470 Ohms	+ OUT
Negative In	1	C5	5	L2	L2	2	COMMON	- IN
Negative Out	6	C6	6	L2	L2	2	COMMON	- OUT
Remote Indicator Positive	4	L1	N/A	L1 IN	L1 IN	N/A	N/A	N/A
Remote Indicator Negative	5	S3	N/A	-R	-R	N/A	N/A	N/A
End of Line Device	Active End of Line	3K3 Resistor	3K3 Resistor	Active End of Line	3K3 Resistor	To Suit Detector Base	To Suit Detector Base	To Suit Detector Base
Head Removal Supported	Yes	Yes	No	Yes	No			

Sense Zone Wiring Diagrams

Find the detector bases you will be using in the table on page 10 and check to see which end of line device is required - either a 3k3 resistor or an active end of line unit. The 3k3 resistor should be used if a zone is comprised entirely of call points.

Sense zone with a 3k3 end of line resistor.

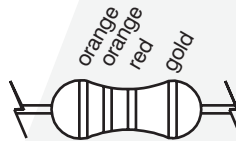
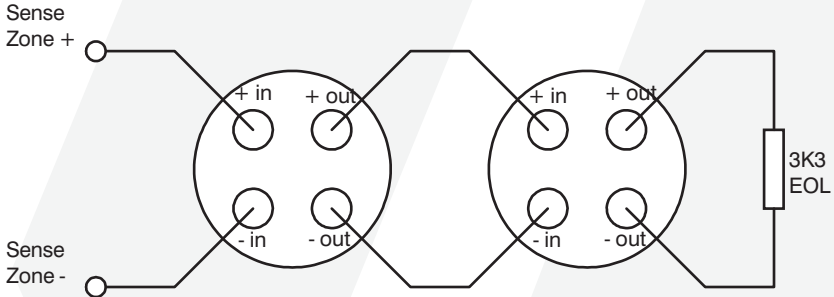

The colour bars on a 3k3 resistor are

Sense zone with an active end of line.

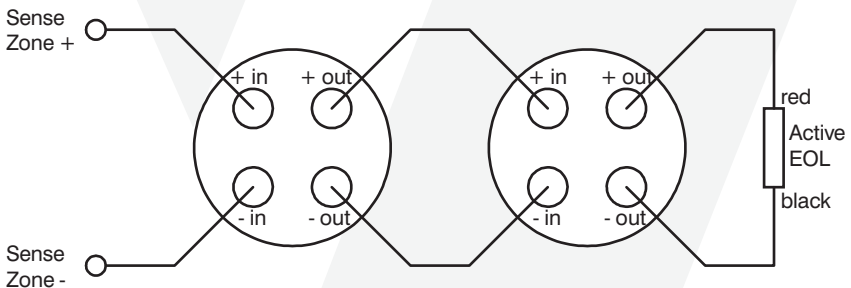

The panel is supplied with 3k3 end of line resistors as standard. Active end of line units are available separately.

Remote indicator connection details are shown in the table on page 10.

Alarm Zone Wiring Diagram

The alarm zones are wired as in the diagram below. A 10k end of line resistor must be fitted at the end of the circuit. Motorised fire bells may be used, but solenoid bells MUST NOT be connected to the panel.

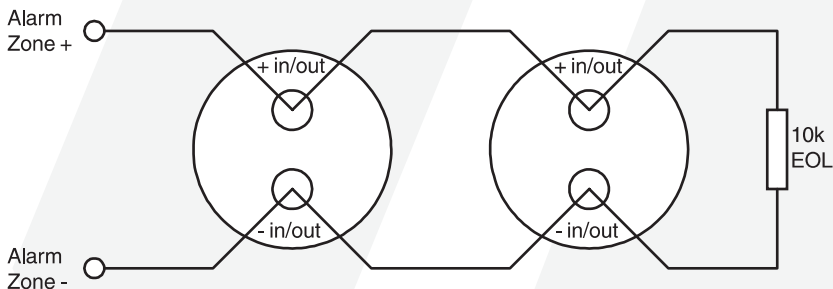

The colour bars on a 10k resistor are



Attaching a relay to an alarm zone.

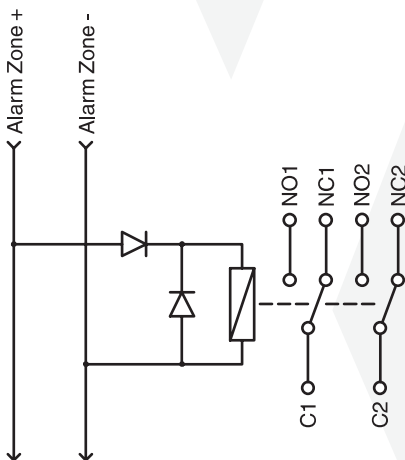

A relay may be connected anywhere on the alarm zone wiring provided that two diodes (1N4001 or equivalent) are fitted as shown in the diagram. The end of line resistor is not shown, but must be connected at the end of the alarm zone wiring. The relay must have a 24V DC coil.

Alternatively (Saffire+ only), a relay can be connected to the Aux 28V terminals, however a diode must still be connected across the coil.

Additional Wiring Information

Connecting a relay to the auxiliary fault (AF) output.

A fault relay can be connected to the panel as shown. The diode (1N4001 or equivalent) must be fitted. The relay must have a 24V DC coil. The relay will normally be energised, dropping out if the panel signals a fault condition. The 0V of the external 28V supply must be connected to the 0V terminal of the Firetrax, or the 'Aux 28V -' terminal of the Firetrax.

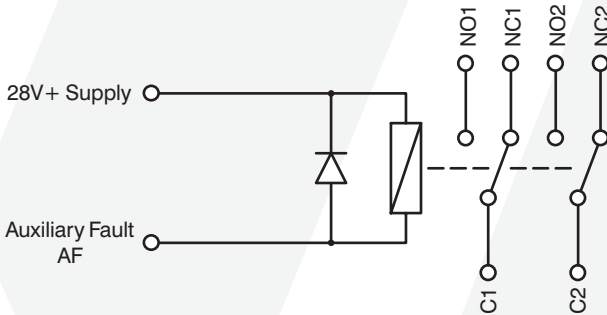

Ring the alarms remotely (Firetrax FT6EN/T+ only).

The class change (CC) facility allows a remote source to sound the alarms. When the CC terminal is connected to the 'Aux 28V -' terminal, the alarms will sound.



Signalling fire to another panel.

By connecting two panels as shown below, when panel B closes its auxiliary contacts, panel A will go into fire. If the zone on panel A is set to non-latching it will automatically reset when panel B opens its auxiliary contacts. If both panels need to signal fire to each other, simply duplicate the circuit substituting panel A for panel B and vice versa.

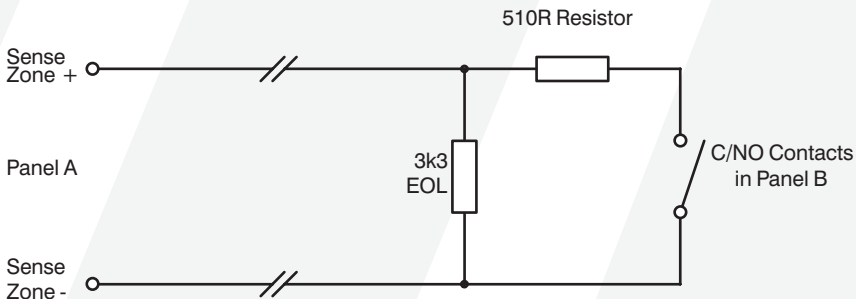

Connecting magnetic door holders.

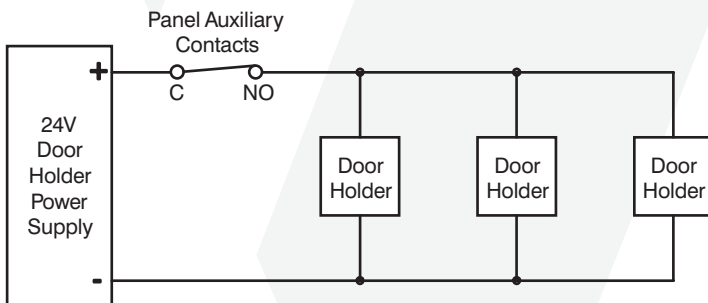

Low voltage magnetic door holders can be switched using a set of auxiliary contacts in the panel. When the panel goes into fire, power to the door holders is removed allowing the doors to close. Care must be taken to ensure that the auxiliary contacts rating of 24V / 1A is not exceeded. Mains voltages **MUST NOT** be switched directly from the auxiliary contacts - instead, fit a heavy duty relay operated from the auxiliary contacts.





User Operating Instructions

FIRETRAX - FT6EN/T

WITH CONTROL KEY TO ON POSITION:

-  Pressing Key 1 will reset the panel providing the alarms have been silenced.
-  Pressing Key 2 once will silence the sounders in a fire condition or silence the buzzer in a fault condition. Pressing Key 2 twice will resound the alarms.

-  Pressing Key 3 will cause the panel to enter test mode. See manual.
-  Pressing Key 4 will cause the panel to enter disable mode. See manual.

FIRE ALARM SYSTEM

CERTIFICATE OF INSTALLATION / COMMISSIONING

Protected area _____

Address _____

Contact Name: _____ Tel: _____

My attention has been drawn to the recommendations of BS 5839:Part 1:1988; in particular, to clauses 14 (false alarms), 28 and 29 (user responsibilities)

In accordance with BS 5839:Part 1988, subclause 26.1, record drawings and operating instructions have been supplied and received by:

Signed _____ Status _____ Date _____

Printed _____

Responsible person for and on behalf of (user) _____

In accordance with BS 5839:Part 1:1988, subclause 26.2, the installation has been inspected and been found to comply with the recommendations of the code.

In accordance with BS 5839:Part 1:1988, subclause 26.3, the insulation of cables and wires has been tested.

In accordance with BS 5839:Part 1:1988, subclause 26.4, the earthing has been tested.

In accordance with BS 5839:Part 1:1988, subclause 26.5, the entire system has been tested for satisfactory operation.

In accordance with BS 5839:Part 1:1988, subclause 26.6, it is certified that the installation complies with the recommendations of the code, other than the following deviations;

In accordance with BS 5839:Part 1:1988, subclause 26.7, it is certified that the handover complies with the recommendations of the code.

Signed (Commissioning engineer) _____ Date _____

Printed _____

For and on behalf of (installer) _____

Address _____

Contact Name _____ Tel: _____

The system log book is situated _____

The system documentation is situated _____